

9225 State Route 66 • Piqua, OH 45356
(937) 773-3493
Catalog updates available at HampshireCabinetry.com/catalogs

Contents

Custom vs Stonebridge D-2
Dimensions, Framed D-9 - D-10
Dimensions, Frameless D-11 - D-12
Finish Characteristics D-7
Series 310 Specifications, Framed. . . . D-3
Series 310 Specifications, Frameless . . D-4
Series 3000 Specifications, Framed . . . D-5
Series 3000 Specifications, Frameless . D-6
Wood Characteristics D-8



vs.



While there are many similarities between the Hampshire Custom and the Stonebridge Semi-custom lines including box construction, finish and, most importantly, the group of people manufacturing and offering customer service, there are also some key differences between the lines.

Drawer Boxes

Dovetailed 5/8" thick Solid Aspen, prefinished before assembly so dovetail is unfinished. Lower drawer boxes (except specialty drawers i.e. file drawers) 6" high. 1/4" plywood bottom.

Dovetailed 5/8" thick Maple, finished after assembly so dovetail is finished. Lower drawer boxes made at maximum height possible for opening. 1/4" plywood bottom.

Drawer Slides

DS-Pro full extension soft-close slides
Can be upgraded to Blum or Blum Heavy Duty slides.

Blum full extension soft-close slides
Can be upgraded to Blum Heavy Duty slides.

Hinges

Overlay (framed) - Blum Soft Close
Frameless - DS-Pro Soft Close
Inset - Amerock decorative hinge (can be upgraded to soft close or inset concealed)

Overlay (framed) - Blum Soft Close
Frameless - Blum Soft Close
Inset - Amerock decorative hinge w/ soft-close earth magnets or Inset concealed hinges w/ soft-close

Wood Species

Red Oak, Walnut, Maple, Cherry, Clear Alder, Knotty Alder, Rustic Walnut, Common Walnut

Red Oak, Walnut, Maple, Cherry, Clear Alder, Knotty Alder, Rustic Walnut, Common Walnut, **Select Walnut, Rustic Cherry, Knotty Pine, Mahogany, Quarter Sawn White Oak**

Finishes

All standard finishes available except Wellington, crackle finish

All standard finishes available and will match any finish technique of other manufacturers.

Custom Colors

Available for 2% finish upcharge

Available for no upcharge

Size Modifications

Can increase/decrease width, height and depth of cabinetry to 1/16" increments. 15% charge for increase in size above standard (every 4" in depth and 3" in width and height). No charge to decrease - priced as next sized cabinet

Can increase/decrease width, height and depth of cabinetry to 1/16" increments. 10% charge for increase in size above standard (every 4" in depth and 3" in width and height). No charge to decrease - priced as next sized cabinet

Pull Out Trays

3" high w/ no scoop in front - same construction as drawers.

4" high or 8" high w/ scoop in front - same construction as drawers.

Finished Shelves

3/4" Plywood (310 series) or Particleboard (110 series) edge banded and finished to match exterior.

3/4" Solid wood finished to match exterior.

Miscellaneous

The backs of the doors/drawerheads are not finished/sanded as well in our Stonebridge line (e.g. we do not fill pin-holes or hand sand). We will not do a true Flush Finished side in Stonebridge, although all of our finished ends are "flush" with the faceframe. There is a seam where the facing meets the side.

Our custom line is truly a custom line. We can manufacture cabinetry in any wood species or finish. Just because you don't see it in our catalog doesn't mean we can't do it. Always ask and we can provide you with a quote and drawing.



Framed Series Specifications - Stonebridge

310 Series	
Material Specs	
Top, Bottom, and Unexposed Ends	1/2" thick plywood, catalyzed varnish topcoat.
Back	1/4" thick plywood, catalyzed varnish topcoat.
Exposed Ends	3/4" thick veneer core plywood with exterior face having matching wood species (same as frame and door). 1/32" lip on face frame.
Face Frames	3/4" thick by 1-1/2" solid wood.
Wall Cabinets	Drilled to receive metal shelf pins for adjustability.
Wall Shelves	3/4" veneer core plywood edge banded. NOTE: Cabinet with finished interior has 3/4" plywood shelves finished to match exterior.
Base Cabinets	Drilled to receive metal shelf pins for adjustability.
Base Shelves	3/4" veneer core plywood edge banded, 15-1/2" deep. NOTE: Cabinet with finished interior has 3/4" plywood shelves finished to match exterior.
BX Shelves	3/4" birch veneer core plywood edge banded, 22-3/4" deep. NOTE: Cabinet with finished interior has 3/4" plywood shelves finished to match exterior.
Mounting Braces	Interior 3/4" x 1-1/2" solid wood. Exterior wood cleat
Toekick	1/2" to 3/4" material, unfinished.
Drawer Boxes	Dovetailed 5/8" thick solid wood front, back and sides, bottoms are 1/4" prefinished plywood. Catalyzed varnish topcoat.
Drawer Slides	Full extension, undermount soft close slides.
Hinges	Concealed hinges with built-in soft-close are used on 1/2" and 1-1/4" overlay doors. Adjustable semi-concealed butt hinges used on inset doors. Concealed inset hinges with soft close available.
Construction Specs	
	Face frames are fastened with screws and glue. Tops and bottoms are plowed, glued, and pinned into sides of cabinet. Sides are plowed, glued, and power fastened into stiles of face frame. Tops and bottoms are fastened to face frame with a 3/4" x 3/4" hardwood cleat. Doors with frames are tongue and grooved together using glue and pins. All wall cabinet bottoms are unfinished. The unexposed ends of wall cabinets are held up 5/16" from bottom to allow for 1/4" pre finished panel to be attached after installation. Exposed ends plowed so panel can be butted into ends. Finished Wall Bottom Panel (FWBP) in Section G.
Finish Specs	
Interiors	Plywood, sanded & sealed with a catalyzed sealer, top coated with a catalyzed varnish.
Exteriors	Stain: hand-wiped, sealed with a catalyzed sealer, sanded, and top coated with a rubbed effect catalyzed finish. Paint: primered, sanded, and painted.



Frameless Series Specifications - Stonebridge

310 Series	
Material Specs	
Top, Bottom, and Unexposed Ends	1/2" thick plywood, catalyzed varnish topcoat.
Back	1/4" thick plywood, catalyzed varnish topcoat. 1/2" thick plywood hanging strips attached to exterior back at top & bottom.
Exposed Ends	3/4" thick plywood with exterior face having matching wood species (same as door). 1/32" lip on face frame.
Wall Cabinets	Drilled to receive metal shelf pins for adjustability.
Wall Shelves	3/4" veneer core plywood edge banded. NOTE: Cabinet with finished interior has 3/4" plywood shelves finished to match exterior.
Base Cabinets	Drilled to receive metal shelf pins for adjustability.
Base Shelves	3/4" veneer core plywood edge banded, 15-1/2" deep. NOTE: Cabinet with finished interior has 3/4" plywood shelves finished to match exterior.
BX Shelves	3/4" veneer core plywood edge banded, 22-3/4" deep. NOTE: Cabinet with finished interior has 3/4" plywood shelves finished to match exterior.
Mounting Braces	Interior 3/4" x 1-1/2" solid wood. Exterior wood cleat
Toekick	1/2" to 3/4" material, unfinished.
Drawer Boxes	Dovetailed 5/8" thick solid wood front, back and sides, bottoms are 1/4" prefinished plywood. Catalyzed varnish topcoat.
Drawer Slides	Full extension, undermount soft close slides.
Hinges	Concealed hinge, 5/8" overlay, 3-way adjustable with soft close..
Construction Specs	
	Tops and bottoms are joined to cabinet ends using hardwood dowels glued. Backs are dadoed into tops, bottoms, and ends, and are glued, pinned, and hot melt glued. Edge banding on face of cabinet matches the wood species of doors.
Reveal	
	1/8" reveal on all sides.
Finish Specs	
Interiors	Plywood, sanded & sealed with a catalyzed sealer, top coated with a catalyzed varnish.
Exteriors	Stain: hand-wiped, sealed with a catalyzed sealer, sanded, and top coated with a rubbed effect catalyzed finish. Paint: primered, sanded, and painted.

Framed Series Specifications - Elite

3000 Series	
Material Specs	
Top, Botton, and Unexposed Ends	1/2" thick plywood, catalyzed varnish topcoat.
Back	1/4" thick plywood, catalyzed varnish topcoat.
Exposed Ends	3/4" thick veneer core plywood with exterior face having matching wood species (same as frame and door). 1/32" lip on face frame.
Face Frames	3/4" thick by 1-1/2" solid wood.
Wall Cabinets	Drilled to receive metal shelf pins for adjustability.
Wall Shelves	3/4" veneer core plywood edge banded. NOTE: Cabinet with finished interior has 3/4" solid wood shelves. Must specify nose detail.
Base Cabinets	Drilled to receive metal shelf pins for adjustability.
Base Shelves	3/4" veneer core plywood edge banded, 15-1/2" deep. NOTE: Cabinet with finished interior has 3/4" solid wood shelves. Must specify nose detail.
BX Shelves	3/4" veneer core plywood edge banded, 22-3/4" deep. NOTE: Cabinet with finished interior has 3/4" solid wood shelves. Must specify nose detail.
Mounting Braces	Interior 3/4" x 1 1/2" solid wood. Exterior 13/16" x 5/8" solid wood .
Toekick	1/2" to 3/4" material, unfinished.
Drawer Boxes	Dovetailed 5/8" thick solid wood front, back and sides, bottoms are 1/4" prefinished plywood. Catalyzed varnish topcoat.
Drawer Slides	Blum Motion - Full extension, zinc coated, concealed rollers that are permanently lubricated. Automatic latching devices, easy release for drawer removal. 75 lb. Dynamic, 100 lb. Static weight capacities. Blum Motion feature takes control of drawer 2" from closing and softly closes and holds drawer in place.
Hinges	Concealed hinges with built-in soft-close are used on 1/2" and 1-1/4" overlay doors. Adjustable semi-concealed butt hinges used on inset doors. Concealed inset hinges with soft close available.
Construction Specs	
	Face frames are fastened with screws and glue. Tops and bottoms are plowed, glued, and pinned into sides of cabinet. Sides are plowed, glued, and power fastened into stiles of face frame. Tops and bottoms are fastened to face frame with a 3/4" x 3/4" hardwood cleat. Doors with frames are tongue and grooved together using glue and pins. All wall cabinet bottoms are unfinished. The unexposed ends of wall cabinets are held up 5/16" from bottom to allow for 1/4" pre finished panel to be attached after installation. Exposed ends plowed so panel can be butted into ends. Finished Wall Bottom Panel (FWBP) in Section G.
Finish Specs	
Interiors	Plywood, sanded & sealed with a catalyzed sealer, top coated with a catalyzed varnish.
Exteriors	Stain: hand-wiped, sealed with a catalyzed sealer, sanded, and top coated with a rubbed effect catalyzed finish. Paint: primered, sanded, and painted.

Frameless Series Specifications - Elite

3000 Series	
Material Specs	
Top, Bottom, and Unexposed Ends	3/4" thick plywood, catalyzed varnish topcoat.
Back	1/4" thick plywood, catalyzed varnish topcoat. 1/2" thick plywood hanging strips attached to exterior back at top & bottom.
Exposed Ends	3/4" thick plywood with exterior face having matching wood species (same as door) and interior having natural finished veneer with catalyzed topcoat finish. 1/32" lip on face frame.
Wall Cabinets	Drilled to receive metal shelf pins for adjustability.
Wall Shelves	3/4" veneer core plywood edge banded. NOTE: Cabinet with finished interior has 3/4" solid wood shelves. Must specify nose detail.
Base Cabinets	Drilled to receive metal shelf pins for adjustability.
Base Shelves	3/4" veneer core plywood edge banded, 15-1/2" deep. NOTE: Cabinet with finished interior has 3/4" solid wood shelves. Must specify nose detail.
BX Shelves	3/4" veneer core plywood edge banded, 22-3/4" deep. NOTE: Cabinet with finished interior has 3/4" solid wood shelves. Must specify nose detail.
Mounting Braces	Interior 3/4" x 1-1/2" solid Maple. Exterior wood cleat
Toekick	1/2" to 3/4" material, unfinished.
Drawer Boxes	Dovetailed 5/8" thick solid wood front, back and sides, bottoms are 1/4" prefinished plywood. Catalyzed varnish topcoat.
Drawer Slides	Blum Motion - Full extension, zinc coated, concealed rollers that are permanently lubricated. Automatic latching devices, easy release for drawer removal. 75 lb. Dynamic, 100 lb. Static weight capacities. Blum Motion feature takes control of drawer 2" from closing and softly closes and holds drawer in place.
Hinges	Concealed hinge, 5/8" overlay, 3-way adjustable with soft close.
Construction Specs	
	Tops and bottoms are joined to cabinet ends using hardwood dowels glued. Backs are dadoed into tops, bottoms, and ends, and are glued, pinned, and hot melt glued. Edge banding on face of cabinet matches the wood species of doors.
Reveal	
	1/8" reveal on all sides.
Finish Specs	
Interiors	Plywood, sanded & sealed with a catalyzed sealer, top coated with a catalyzed varnish.
Exteriors	Stain: hand-wiped, sealed with a catalyzed sealer, sanded, and top coated with a rubbed effect catalyzed finish. Paint: primered, sanded, and painted.

Finish Characteristics

- General:** The Hampshire Co. uses only the finest finishing products in its cabinetry. It is important to realize the beauty of finished wood allows the natural qualities of the wood to show through the stain. Each wood species has its own distinct color. This color will vary from pink, red, white, green, yellow, or black, and is caused by minerals and acids in the soil where the tree was planted. The appearance of wood is constantly changing from the effects of light and humidity. All wood darkens with age and new cabinetry may appear somewhat lighter than older samples, a display, or color blocks.
- Stain Finishes:** The Hampshire Co. employs a seven step staining process in its cabinetry. These steps include machine sanding, hand sanding, cleaning, hand wiping of stain, catalyzed sealer coat, hand sanding again, and application of a catalyzed varnish top coat. Catalyzed varnish is resistant to most household chemicals, such as detergent, fingernail polish remover, and fruit juices.
- Paint Finishes:** Our paint process employs six steps. These steps include machine sanding, hand sanding, cleaning, application of a catalyzed primer, hand sanding again, and application of a catalyzed paint top coat. Painted finishes are resistant to most household chemicals. By nature, all wood expands and contracts with the changes in temperature and humidity. When this occurs, hairline cracks may develop in the joints of cabinetry. These cracks will not affect the durability of the paint system and are considered acceptable.
- Glazing:** This is a process used to accentuate the carved portions of doors, molding, etc. It is a stain material, which is applied between the sealer coat and the top coat.
- Brushed and Accented:** This is a combination process which is achieved by lightly sanding the finish in the direction of the wood grain, and then applying a light coat of glazing. The glaze is allowed to build up in the corners and the details of the door. A clear coat of catalyzed varnish is then applied over the glaze.
- Country Finishes:** Country is a distressed finish that gives the appearance of an old, worn look. It is available on any of the wood species. Several steps are involved in achieving this look. We begin with machine sanding, hand sanding, and painting an undercoat of color, after which the distressing is applied. This involves applying dents, worm holes, and simulated cracks, plus the undercoat of paint or stain is randomly sanded through on the edges, followed by glazing, then a sealer coat. After hand sanding, a clear, catalyzed top coat is applied.
- Distressing:** The Hampshire Co.'s definition of distressing includes the following: worn edges, worm holes, knife cuts, and hammer marks. Any combination of distressing is available.
- Accented:** Similar to glazing, this material is used to accentuate carved portions of doors, molding, etc. It is applied after the top coat is dry and then a clear coat of catalyzed varnish is applied over the accent.
- Brushed:** Brushed process is the same as paint finish, with the addition of a special sanding and glazing process. After painting, the cabinets are sanded with the grain of the wood using a fine grit sandpaper. A colored glaze is then applied. After drying, a clear coat of catalyzed varnish is applied to protect the glaze. This particular process, that a sample block be ordered before ordering cabinetry.
- Cerused:** Cerusing color is applied to gather in wood grain before staining. Cerusing only available on woods with open grain.

Finish Characteristics, cont.

Crackle: This is a process that can be applied onto a stain base or a paint base. The amount and size of the crackling is unpredictable and irregular throughout which gives a natural, realistic aged appearance. The Hampshire Co. suggests applying a glaze to better enhance the crackling effect. Once the crackling process is achieved, a clear catalyzed topcoat is applied. It is advised, on this particular process, that a sample block be ordered before ordering cabinetry.



Wellington: This is a process that can be applied onto a stain base or a paint base. The amount and size of the crackling is unpredictable and irregular, and randomly placed, which gives a natural, realistic aged appearance. Includes chipping, worn edges, worm holes, knife cuts, and hammer marks. A glaze is used to better enhance the crackling effect. Once the crackling process is achieved, a clear catalyzed topcoat is applied. It is advised, on



Wood Characteristics

ALDER, CLEAR: A medium weight wood, pale yellow to reddish brown color. Somewhat uniform color, pronounced contrast between end and surface grain.

ALDER, KNOTTY: A medium weight wood, pale yellow to reddish brown color. Somewhat uniform color, pronounced contrast between end and surface grain. Knots will vary in size and tightness but no holes through door will be present.

CHERRY: A hardwood with a noticeable grain pattern. Cherry has gum streaks and bird pecks or pinholes which are not filled in. It may range in color from a vanilla to a deep pink. Cherry darkens when exposed to any kind of light, especially for the first few years after production. This darkening effect will not be even and will be more noticeable in lighter stains. Newly manufactured cherry cabinets will not be the same color as aged cabinets, samples, or color blocks. Because cherry ages, new cherry color blocks should be ordered every 6 months.

HICKORY: A hardwood that has a dramatic color variation from light cream to dark gray. The Hampshire Co.'s finishing process may neutralize this variation but will not eliminate it entirely. Bird pecks or pinholes and small black or brown gum spots are acceptable characteristics in hickory.

RED OAK: A hardwood with a strong grain pattern. This pattern will range from tight knit to open blaze that may form a pointed design known in the trade as the "flame of the oak." Occasional dark pieces of wood or streaks known as "mineral" are common in furniture quality oak. Oak's open grain enhances the stain and brings out the beauty of the wood.

MAPLE: A hardwood with a tight grain pattern. Maple may have quilting or burl marks as a result of undeveloped twigs before milling.

WALNUT, COMMON: A hardwood with both straight and irregular grain pattern. Color can range from a yellowish brown to a rich chocolate brown. Medium weight wood with good stability. Walnut will contain both heartwood and sap wood.

WALNUT, RUSTIC: A hardwood with both straight and irregular grain pattern. Color can range from a yellowish brown to a rich chocolate brown. Medium weight wood with good stability. Rustic Walnut will contain both heartwood and sap wood, with knots and defects.



RUSTIC CHERRY: Same as standard cherry except that some sap wood will appear in face of doors and frames, along with knots of varying sizes and soundness. Available on select door styles.



MAHOGANY: A hardwood with a tight, indistinct grain pattern. It may range in color from light/medium brown to dark brown. It may also contain colors ranging from gray-brown to red. Mahogany is available in 3000 series only on select door styles.



QUARTER SAWN WHITE OAK: Tan to greenish red to brown color, moderately straight grain due to quarter sawing, presents an antique look due to the fact that most antique oak furniture was quarter sawn. Available in 3000 series on select door styles.



KNOTTY PINE: A softwood with a noticeable figure and open grain. Pine has considerable pitch that may ooze out at the surface after being finished. This may result in a slight pebbly surface which is a natural characteristic of pine. Some colors may change around knots. Pine is relatively low in resistance to shock.. Knotty Pine is distressed with hammer marks only and is available in 3000 series only.



SELECT WALNUT: A hardwood with both straight and irregular grain pattern. Color can range from a yellowish-brown to a rich chocolate brown. Medium weight wood with good stability.

The Hampshire Co.'s finishing process enhances the natural characteristics of the woods used in manufacturing its products. This finishing process also shows the natural color and pattern variation that occurs using furniture quality wood.

The Hampshire Co. does not offer materials that are selected to give a matched appearance in pattern or color.

Framed Dimensional Information - Standard

Wall Cabinets

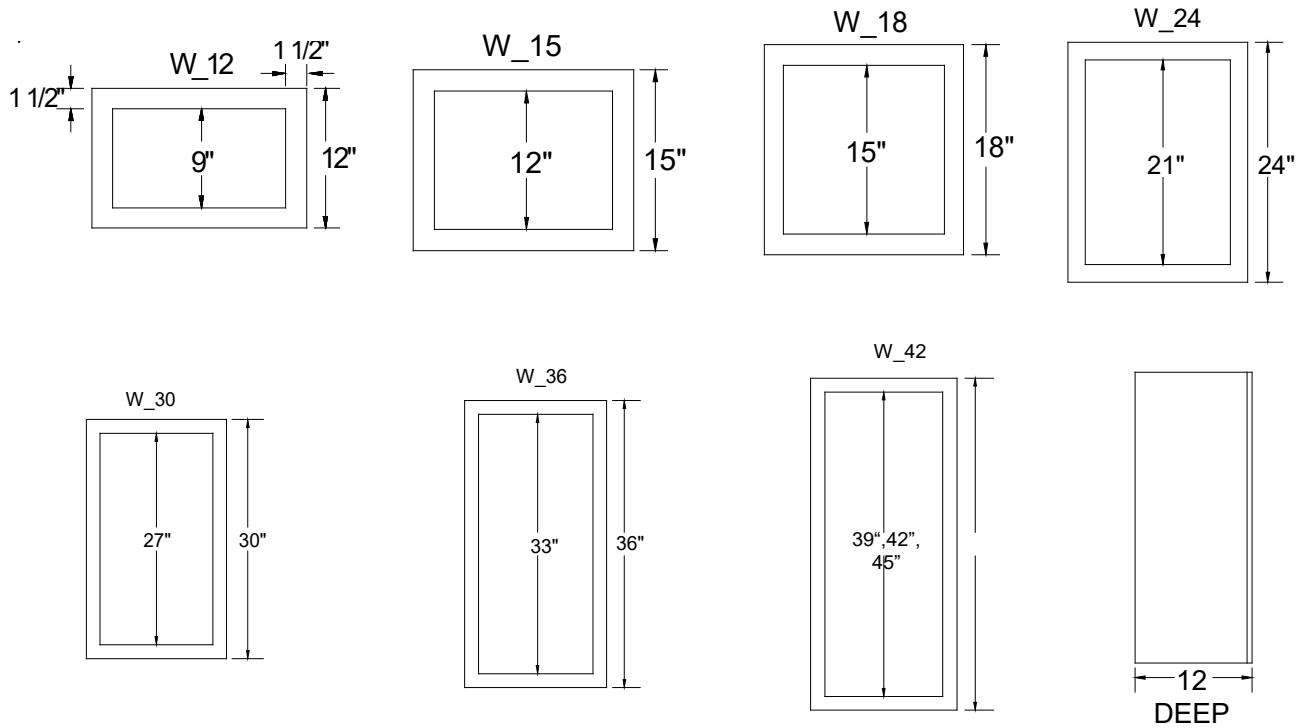

Base Cabinets

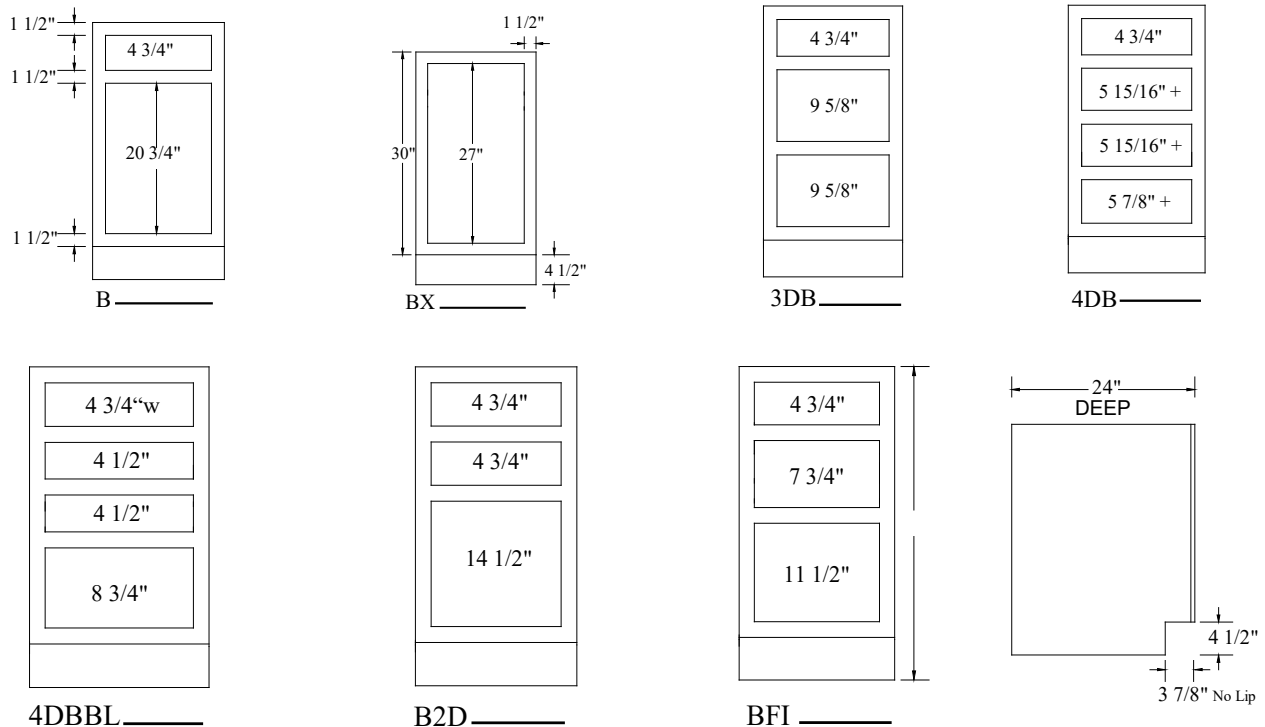

Framed Dimensional Information - Standard

Vanity Cabinets

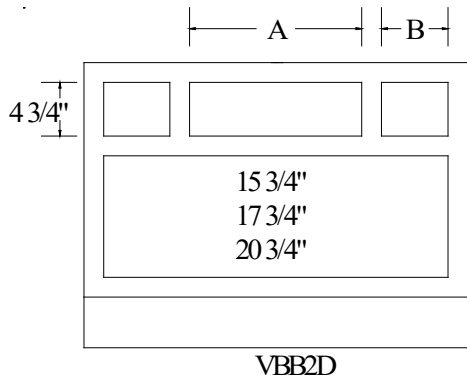
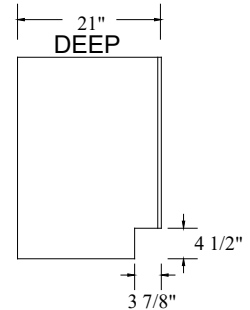
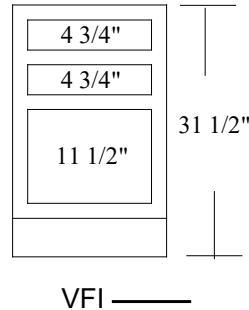
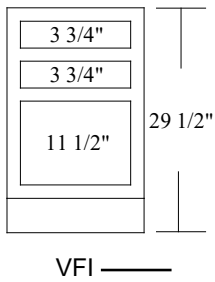
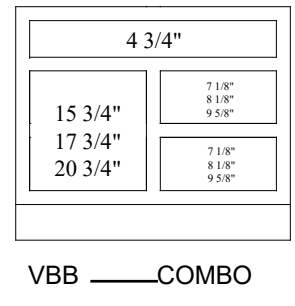
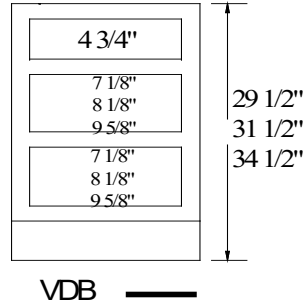
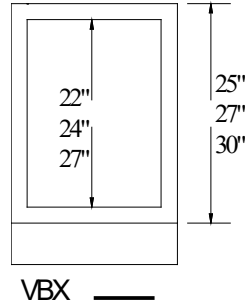
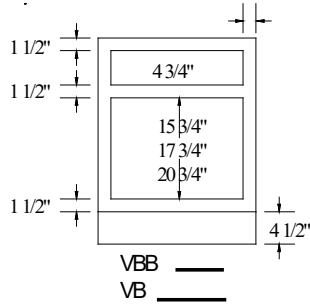

	A	B
VBB2D 36	15"	7 1/2"
VBB2D 39	16"	8 1/2"
VBB2D 42	19"	8 1/2"
VBB2D 45	16"	11 1/2"
VBB2D 48*	19"	11 1/2"

*Has 2 pair of butt doors unless otherwise specified.

Tall Cabinets

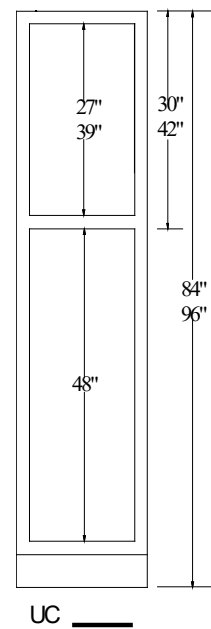
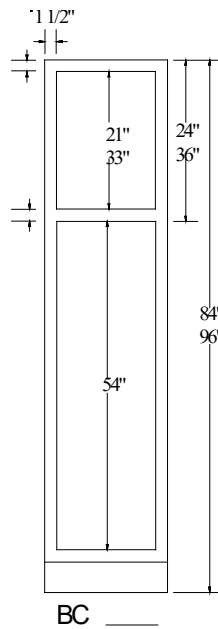

Frameless Dimensional Information - Standard

Wall Cabinets

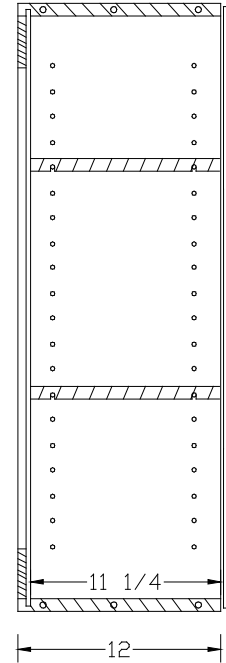
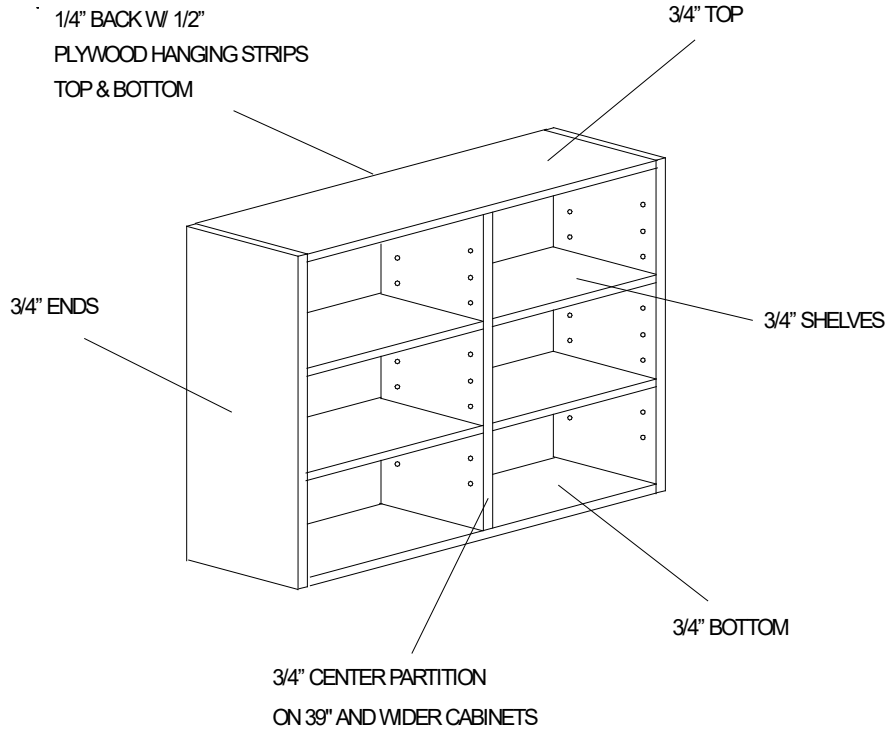

SIDE VIEW

Base Cabinets

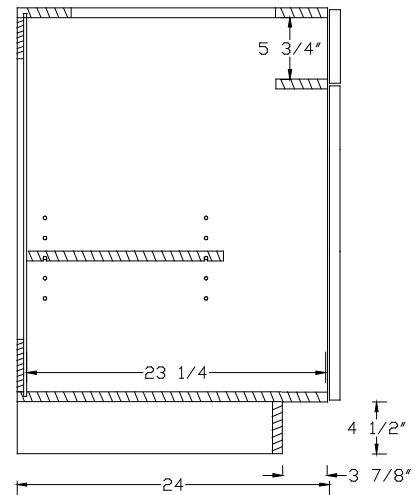
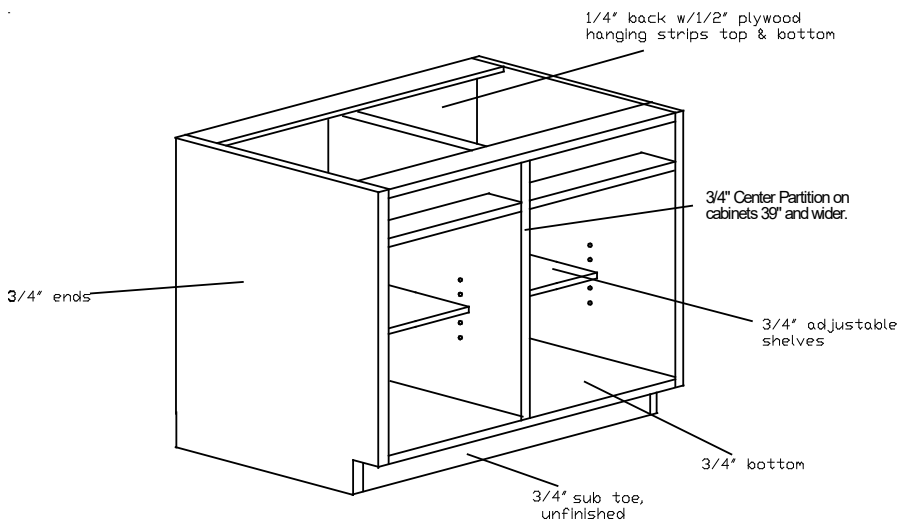

SIDE VIEW

Frameless Dimensional Information - Standard

Vanity Cabinets

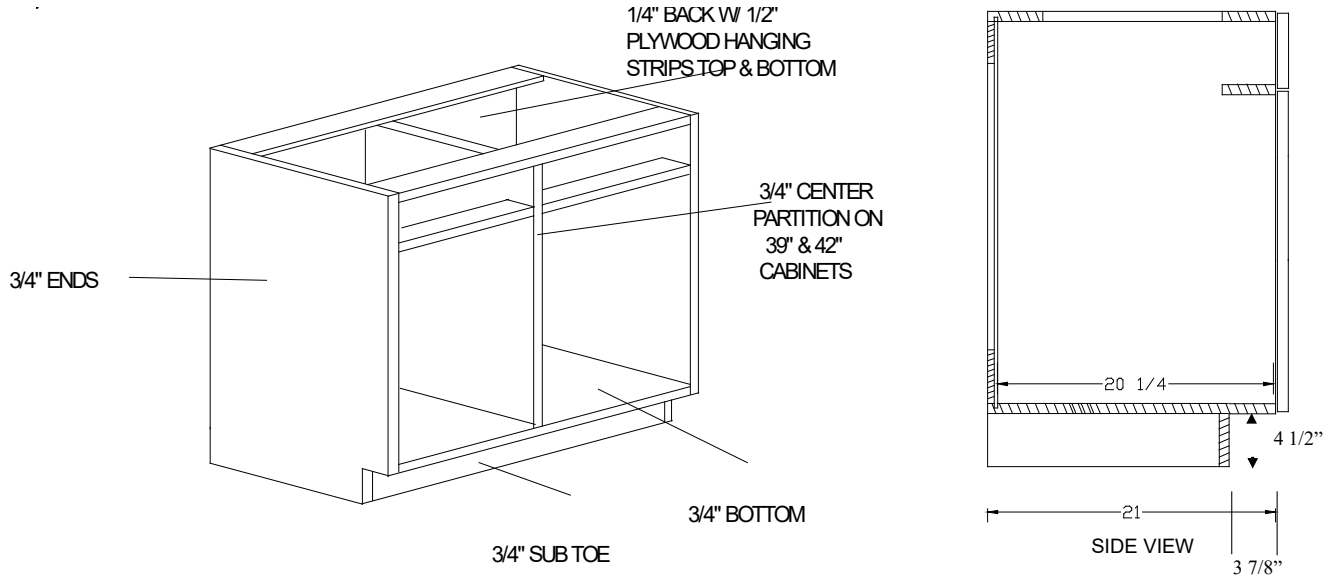

Tall Cabinets

